

UNIT I ESTIMATE OF BUILDINGS

Load bearing and framed structures – Calculation of quantities of brick work, RCC, PCC, Plastering, white washing, colour washing and painting / varnishing for shops, rooms, residential building with flat and pitched roof – Various types of arches – Calculation of brick work and RCC works in arches – Estimate of joineries for paneled and glazed doors, windows, ventilators, handrails etc.

2-MARKS

1. State the units of measurement in MKS for earth work, D.P.C, Brick work and stone work. (May /June 2009,May/June 2012)

Earth work	:	Cu. m or m ³
D.P.C	:	Sq.mor m ²
Brick work	:	Cu. m or m ³
Stone work	:	Sq. m or m ²

2. State the units of measurement in MKS for wood work, Steel work, Plastering and flooring.(May/June 2012)

Wood work	:	Cu. m or m ³
Steel work	:	Quintal or Kg
Plastering	:	Sq. m or m ²
Flooring	:	Sq. m or m ²

3. Give the importance of Estimating.(Nov/Dec 2010)

- i. Estimates can result in efficient use of resources and late delivery.
- ii. Estimates can result in sufficient budget being allocated or excess budget being set aside for the project when it could be used for other projects.
- iii. This can lead to correct decisions about proceeding with the project being made.

4. Name any four items come under “painting” in estimating.(Nov/Dec 2010)

- (i) Painting of doors & Windows Frame
- (ii) Painting of Shutters
- (iii) Iron bars
- (iv) Grill

5. What are the units of measurements for (a) Concrete (b) Roofing?

(Nov/Dec 2010)

- (a) Concrete : Cu. m or m^3
- (b) Roofing : Sq. m or m^2

6. How do you calculate the quantity of brick work in arches? (Nov/Dec 2010)

The quantities of brick work in arch are calculated by multiplying the mean length of arch by *Breadth of wall* & by the *thickness of arch*.

7. What is detailed estimate? (May/June 2009)

- ✓ Detailed estimate is an accurate estimate and consists of working out the quantities of each item of works and working the cost.
- ✓ The dimensions like length, breadth & height of each item are taken out correctly from drawings and quantities of each item are calculated and then abstracting & billing are done
- ✓ The detailed estimate is prepared in two stages.
 - i) Details of measurement & calculation of quantities
 - ii) Abstract of estimate.

8. What are contingencies? (May/June 2009)

The term Contingencies indicates the incidental expenses of miscellaneous charges cannot be classified under any distinct item or sub head; yet pertain to the work as whole.

9. What is work charged establishment? (May/June 2009)

Work charged establishment is the establishment which is charged to works directly. During the construction of a building or a project, a certain number of works – supervisors, mates, munshies, etc., are required to be employed, and their salaries are paid from the amount of work –charged provided in the estimate. For work charged estimate a percentage of 1.5 % to 2.0% of the estimated cost is included in the estimate.

10. List out the types of estimate. (May/June 2012)

- i) Preliminary estimate or Approximate or abstract or rough cost estimate.
- ii) Plinth area estimate
- iii) Cube rate estimate or cubical content estimate
- iv) Approximate quantity method estimate
- v) Detailed estimate or Item rate estimate
- vi) Revised estimate
- vii) Supplementary estimate.
- viii) Supplementary & revised estimate
- ix) Annual repair or maintenance estimate (A.R or A.M estimate)

11. List out different methods adopted for approximate estimation. / What are the different types of approximate method?(May/June 2012, Nov / Dec 2013, May/ June 2016)

- i) Preliminary estimate or Approximate or abstract or rough cost estimate.
- ii) Plinth area estimate
- iii) Cube rate estimate or cubical content estimate
- iv) Approximate quantity method estimate

12. Differentiate Plinth area & carpet area.(May/June 2012)

Plinth area:

- ✓ The buildup covered area by taking the external dimension of the building at the floor level is called plinth area.

- ✓ Court yard, open areas, unenclosed balconies, architectural bands etc., are not included in the plinth area
- ✓ For multistoried buildings the plinth area are measured for each storey separately.

Carpet area:

- ✓ Floor area of the building is the total area between the walls which will be equal to the plinth area minus the area of walls. (This includes floor area of all rooms, verandahs, passages, staircase room bathroom etc)
- ✓ The floor area of verandahs, passages, balconies, entrance halls, staircase room etc which are used for the movements are termed as circulation area.
- ✓ The floor area of kitchen, store room, air conditions, plant room is termed as non liveable areas.
- ✓ Useful area = floor area – (circulation – non liveable area) is termed a carpet area (or) liveable area.
- ✓ In residential building the carpet area will be 55% to 65% of the plinth area.

13. List out various types of arches. (May/June 2012, Nov / Dec 2014) (April/ May 2017)

- i) Segmental arch with span & angle given
- ii) Segmental arch of 60
- iii) Segmental arch with span & rise given
- iv) Semi circular arches
- v) Semi elliptical arches
- vi) Flat arches

14. What is co-efficient meant by painting? (May/June 2012)

Measuring the area of doors & windows for painting, the clear distance between walls is measured on one side & is multiplied by a constant called painting co-efficient to allow for both faces including the sides of frames, grooves, projections etc.

15. Define Estimate.(May/June 2012)

Estimate is prepared by calculating the quantities required then calculating the cost of work at suitable rate to get the expenditure likely to be incurred in the project.

16-MARKS

- 1. Explain the Individual wall method of building estimating. (May/June2009, May/June2012) (8 Marks) (April/ May 2017)**
- 2. Explain the centre line method of building estimating. (May/June2009May/June2012)**
- 3. Explain in detail the different types of estimates (Nov/Dec2010, Nov/Dec2013,May / June 2016)**
- 4. Explain the following approximate estimates: i) Plinth area method ii) Cube rate method / explain the methods used to find the approximate cost of the building. (May/June2009, Nov / Dec 2013,May / June 2016)**
- 5. Explain the Main items of works involved in the construction of building. (May/June2009, Nov/Dec2012)**
- 6. Write short notes on i) Administrative approval ii) Technical sanction (May/June2012) (8marks)**
- 7. The plan and sectional elevation of a building are given in Figure 7(a). Estimate the quantities of the following items of the building. (Nov/Dec-12 & May/June-13)**
- 8. Estimate the quantities of following items shown in figure 7(a). (Nov/Dec 2012 & May/June 2013)**
- 9. Explain the deduction and additions to be applied in the case of estimation of plastering.(April / May 2015) (10 Marks)**
- 10. Prepare a detailed estimate of a shop building consisting of three shops with front verandha from the given Figure 10 for the following.**
 - i. Earthwork in excavation in foundation.**

- ii. 1st class brick – work in 1:6 cement mortar in foundation and plinth**
- iii. 12 mm thick cement plastering 1: 6 in walls**
- iv. White washing 3 coats inside. (Nov / Dec 2015)**

UNIT II ESTIMATE OF OTHER STRUCTURES

Estimating of septic tank, soak pit – sanitary and water supply installations – water supply pipe line – sewer line – tube well – open well – estimate of bituminous and cement concrete roads – estimate of retaining walls – culverts – estimating of irrigation works – aqueduct, syphon, fall.

2-MARKS

1. Define aqueduct. (May / June 2016) (April / May 2017)

When the irrigation channel passes over the drainage or stream, it is usually takes through a masonry or RCC rectangular channel or duct known as aqueduct.

2 .Write the importance of soak pit. (May / June 2016) (April / May 2017)

Disposal effluent from the septic tank may be done by absorption in soil by soak pit. The size and length depend on the number of users and nature of soil.

3. What is lead? (May/June 2012, Nov / Dec 2015)

Normally earth work is estimated for 30m lead or distance. The distance of 30m is known as lead. Normal rate for earthwork in 30 m lead. For greater lead the rate will be different (higher) for every unit of 30m lead. Therefore the earthwork is estimated separately for every 30 m.

4. What is lift? (May/June 2012, Nov / Dec 2015)

Normally earth work is estimated for 1.5m lift or height. The height of 1.5m is known as lift. Normal rate for earthwork in 1.5 m lead. For greater lift the rate will be different (higher) for every unit of 1.5 m lift. Therefore the earthwork is estimated separately for every 1.5 m.

5. What are all the sanitary fittings? / List out the sanitary fittings. (Nov/Dec2011)

Sanitary fitting are various types of traps, Wash basin, kitchen sink, Flushing cistern, water closet, etc.

6. What are the main components of culvert? (Nov/Dec2012) (Nov/Dec 2016)

- i. Abutments
- ii. Wing walls
- iii. Arch

7. What is mean sectional area method? (May/June 2009)

Mean sectional Area method is to calculate quantity of earth work in Mean sectional area i.e. Sectional area of one end plus sectional area of other end divided by two & then multiplied by length

8. State the trapezoidal formula for a series of cross sections. (May/June 2009)

$$\begin{aligned} \text{Series of Trapezoidal formula } V &= \frac{D}{2} [A_0 + 2A_1 + 2A_2 + 2A_3 + \dots + 2A_{n-1} + A_n] \\ &= D \left[\frac{A_0 + A_n}{2} + A_1 + A_2 + A_3 + \dots + A_{n-1} \right] \end{aligned}$$

9. Types of traps? (May/June 2004)

Types of traps based on two ways i) As per shape ii) as per size

- i) As per shape: Q shape, s shape, P shape
- ii) As per size : Floor traps, Gully traps, Intercepting traps

10. Define traps: (May/June 2004)

Traps are used for preventing foul gas sewer to backflow in the house. This is done by providing water seal in the tap

11. Write the unit measurement for the following:-

- a) G. I pipe - meter
- b) Wash hand basin - No's
- c) S. W pipes - meter
- d) Man hole - No's

12. What material is required for laying a water supply pipe line in domestic building?

- 1) Galvanized iron
- 2) Cast iron
- 3) Steel
- 4) Hume steel (cement lined steel)
- 5) R.C.C, P.V.C

13. Write down the expression for calculation of volume by prismoidal formula.

$$\text{Quantity or volume} = L/6 (A_1 + A_2 + 4A_m)$$

Where, $A_1, A_2 = C/S$ area

$L =$ length

$A_m =$ mid sectional area

Quantity or volume

$$\begin{aligned} &= [\text{sec. area of central portion} + \text{sec. area of side slope portion}] \times \text{length} \\ &= [b (d_1+d_2)/2 + Ls/3 (d_1^2 + d_2^2 + 2d_1d_2)] \times L \end{aligned}$$

14. What are the types of culverts?

- (1) Arch culvert
- (2) Slab culvert
- (3) Box culvert
- (4) Pipe culvert

15. Enlist the various types of sewers.

- 1) Storm sewer
- 2) Sanitary sewer
- 3) Egg sewer
- 4) Circular shape sewer
- 5) Based on shape sewer

16-MARKS

1. Prepare a detailed estimate of a Septic tank with Soak-pit for 25 users from the given drawings, Fig.1

Septic tank shall be of first class brickwork in 1:4 cement mortar the foundation and floor shall be of 1:3:6 cement concrete. Inside of septic tank shall be finished with 12mm cement plaster and floor shall be finished with 20 mm cement plaster with 1:3 mortar mixed with standard water proofing compound. Upper and lower portion of soak-pit shall be of second class brickwork in 1:6 cement mortar and middle portion shall be of dry brickwork. Roof covering slabs and baffle wall shall be of precast R.C.C. The length of the connecting pipe from latrine seat may be taken as 3metres. (May / June 2013) (April / May 2017)

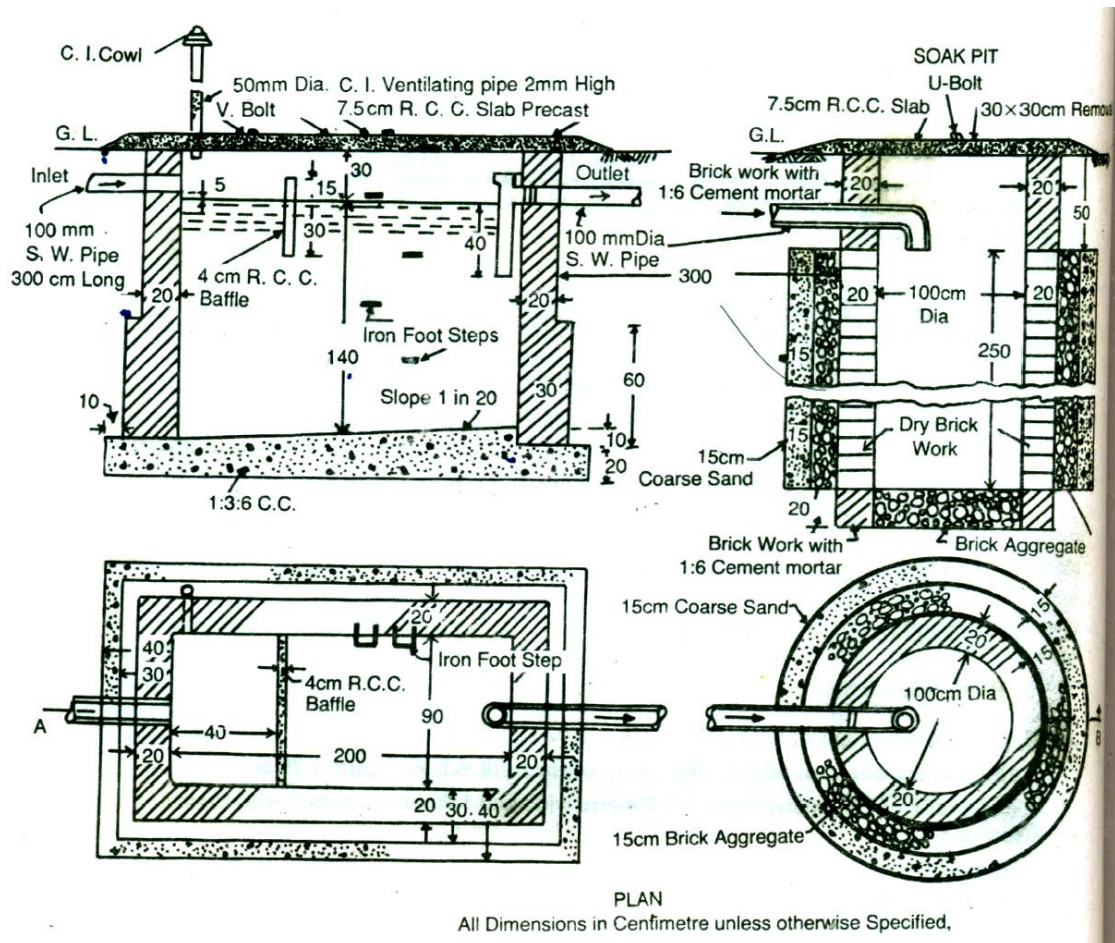
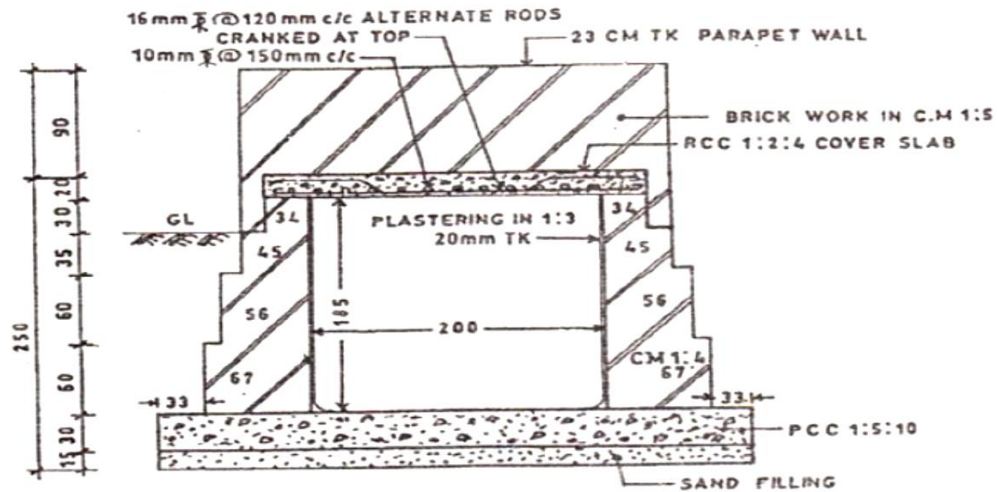

Fig .1

2. Estimate in detail the quantities of the following items of work in a box culvert shown in the accompanying fig.

- a) Earthwork excavation & P.C.C. 1:5:10 for foundation

- b) Plastering with C.M. 1:3-20mm thick.
- c) Brick work in C.M. 1:4 and C.M. 1:5
- d) R.C.C. 1:2:4 – cover slab (May / June 2013)



Cross section of Box culvert

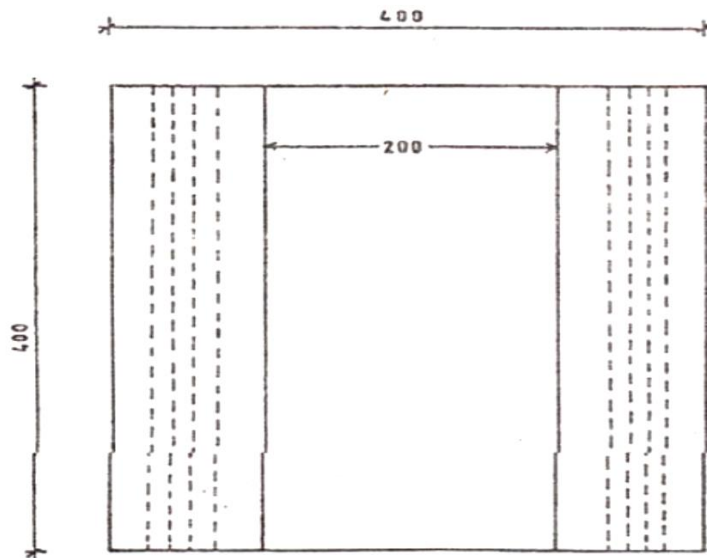

Plan

BOX CULVERT

ALL DIMENSIONS ARE IN CMS.

3. Prepare a detailed estimate for the construction of a new State Highway for one kilometer length. The formation width of road is 10 meter, average height of bank is 1 meter and the side slope 2:1. The metalled width is 3.70 m and

three coats of metalling are to be provided as per cross section. The surface shall be finished with two coats of painting.

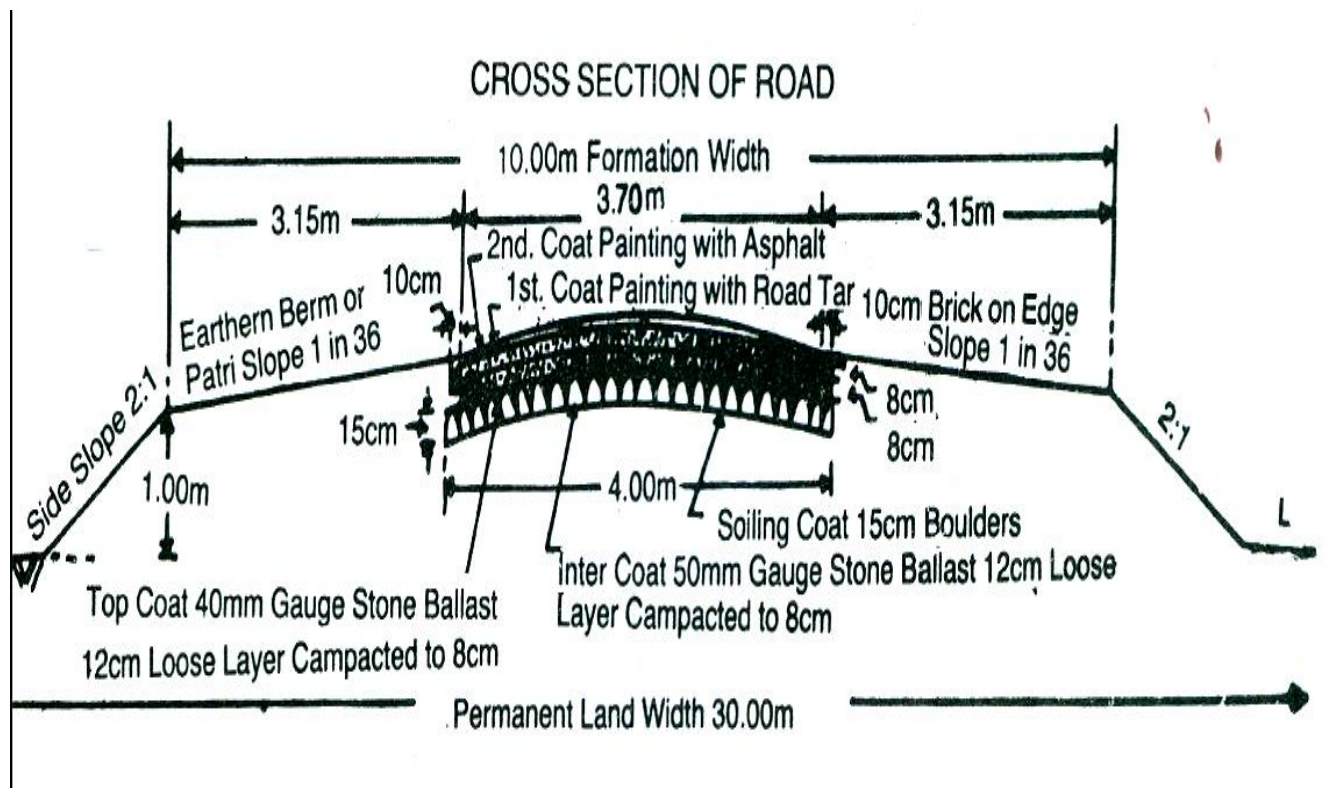

4. Prepare a detailed estimate of a Manhole from the given drawings and general specifications.

General specifications: Foundation and floor concrete shall be of first class in 1: 4 cement mortar and inner faces of wall shall be pointed with 1:2 cement mortar. Inside channels and benching floor shall be finished with 20mm thick plastering with 1:3 cement mortar.

MAN HOLE

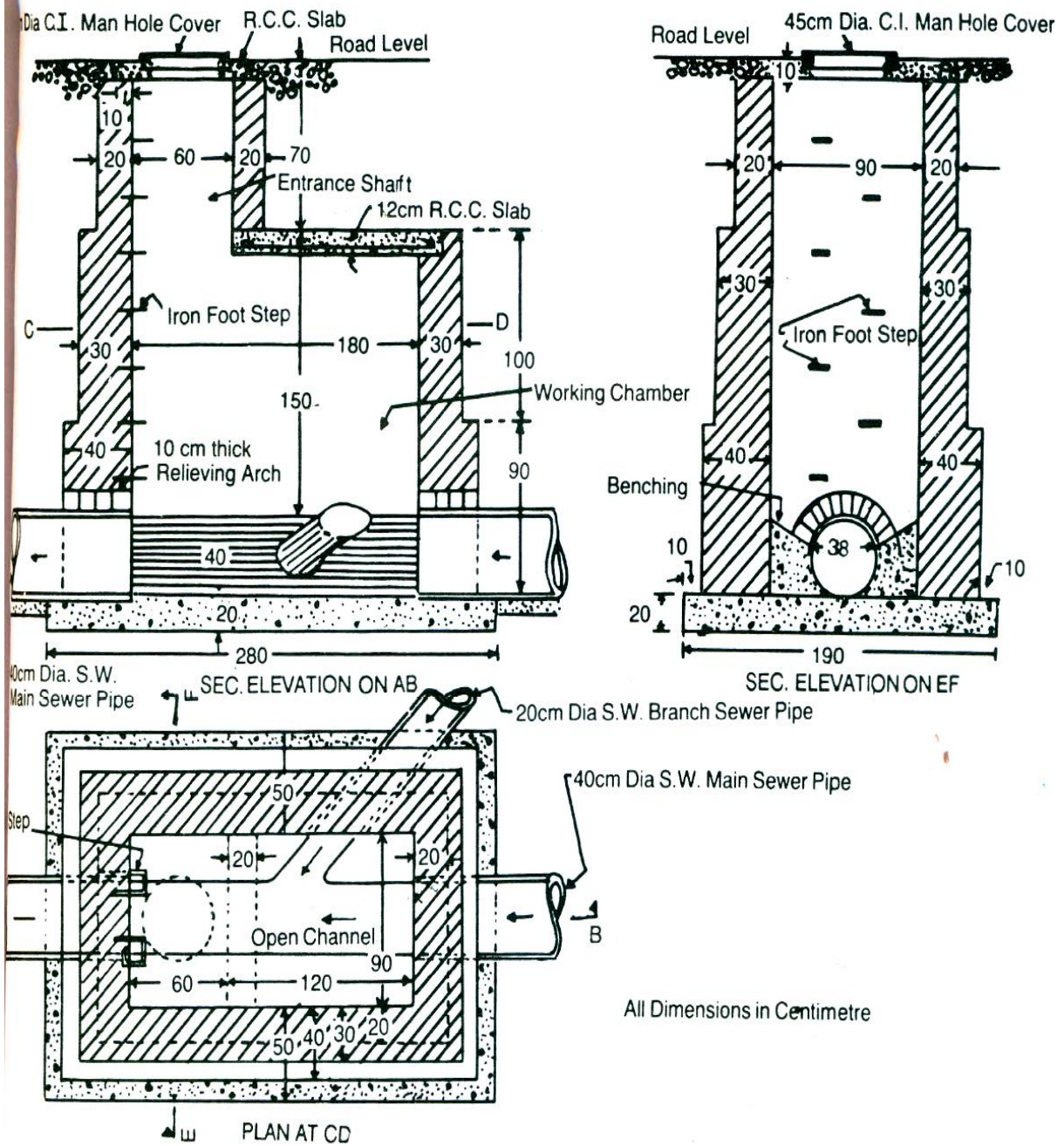

5. Prepare a detailed estimate of a slab culvert of 1.50 span and 4.00 meter roadway from the given drawing. The general specifications are as follows:

Foundation concrete shall be cement concrete 1:3:6 with stone ballast and coarse sand. Masonry shall be of first class brickwork in 1:4 cement coarse sand

mortar. Slab shall be of R.C.C 1:2:4 with reinforcement as per drawing. Exposed surface of brick masonry shall be cement pointed 1:2. Road shall be provided with 10 cm thick wearing coat of 1:2:4 cement concrete.

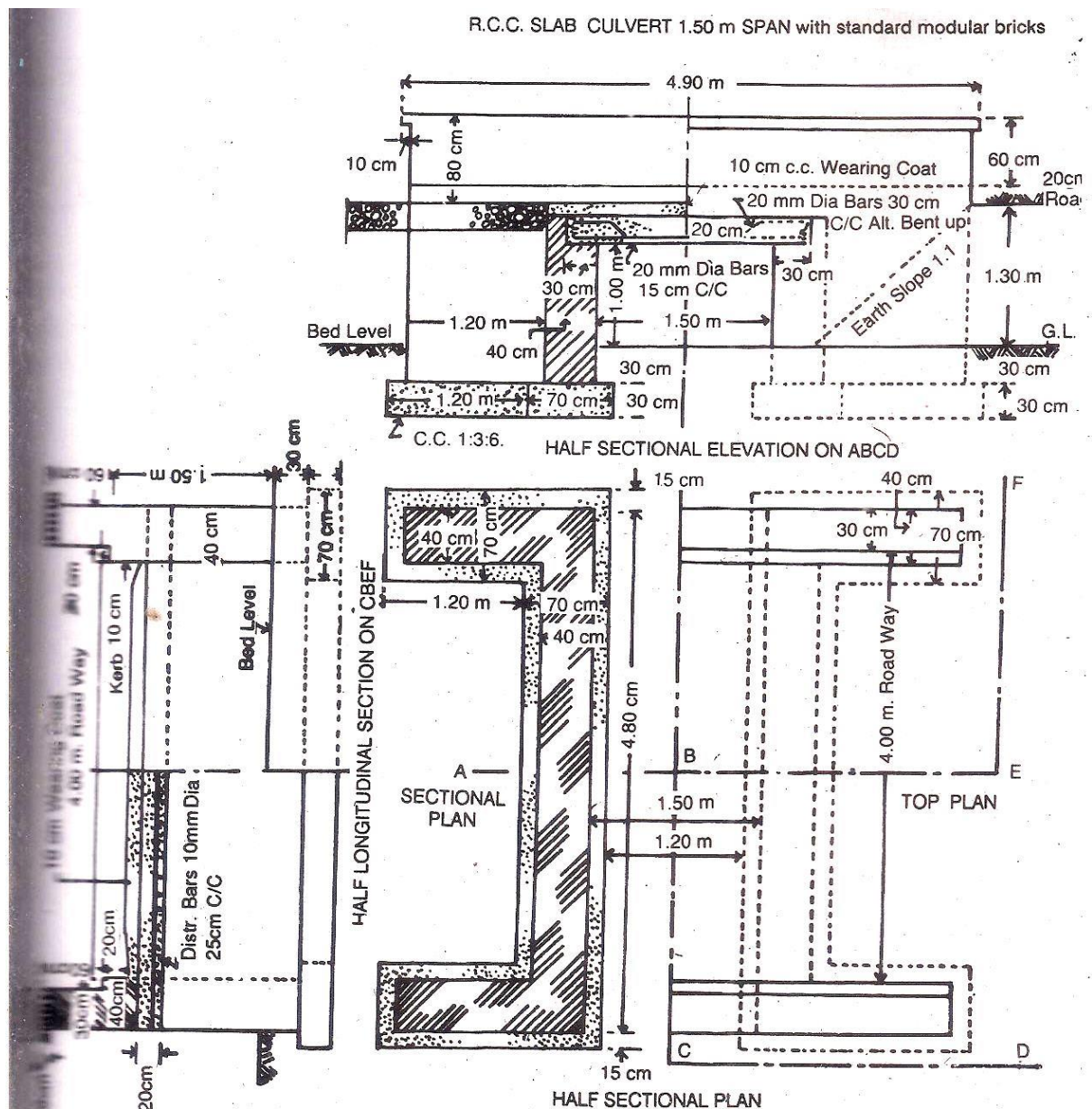

6. Prepare a detailed estimate for an arch culvert of two meter span and 5 meter clear road way from the given drawing. The general specifications are as follows:

Foundation shall be of cement concrete 1:4:8 with over burnt brick ballast and local sand mortar, except arch work which shall be of 1:3 cement and

coarse sand mortar. Exposed surface shall be pointed with 1:2 cement and local sand.(Nov / Dec 2015)

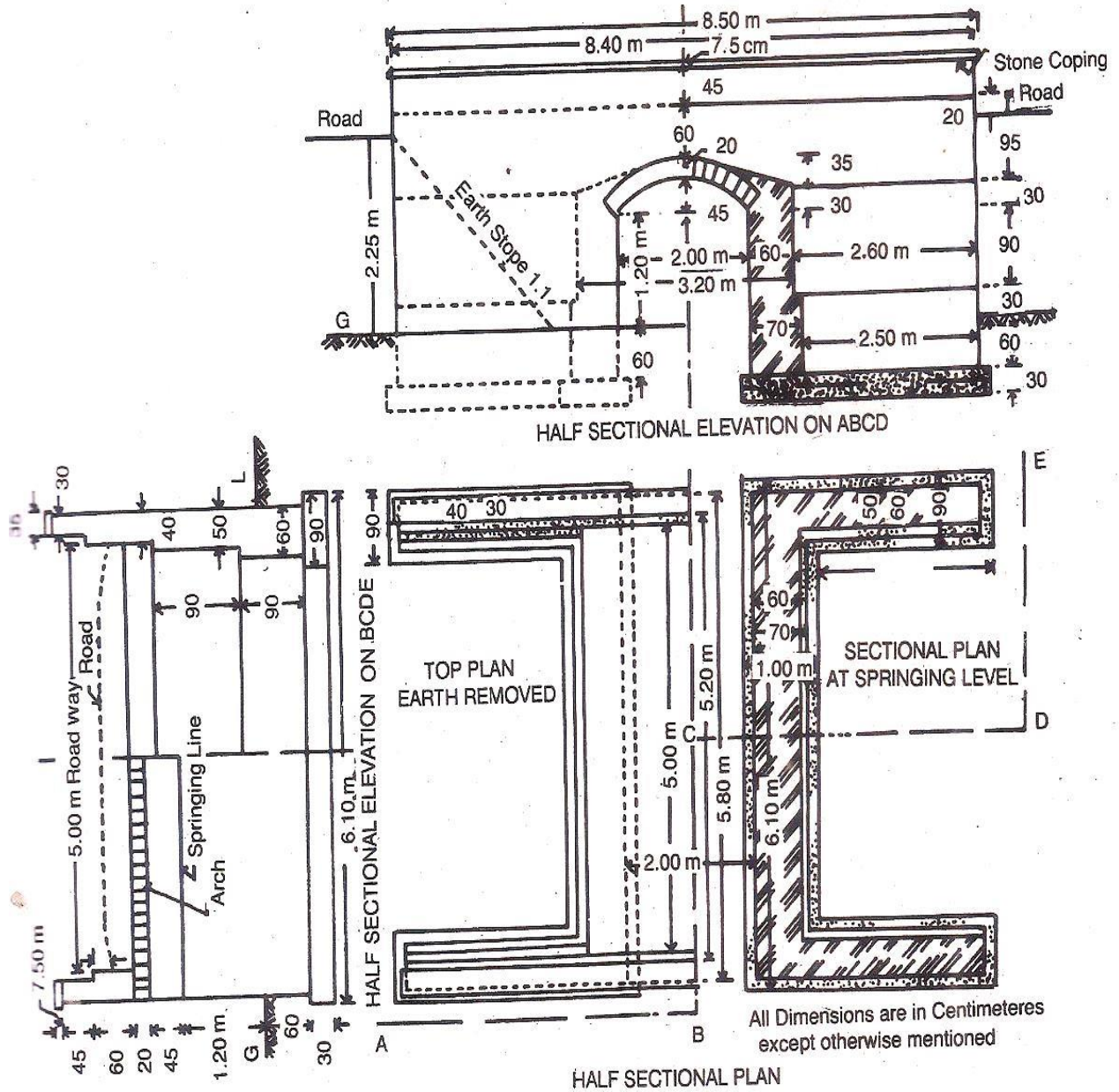

7. (a) Prepare an estimate of a surface drain for 10 m length from the given drawing.

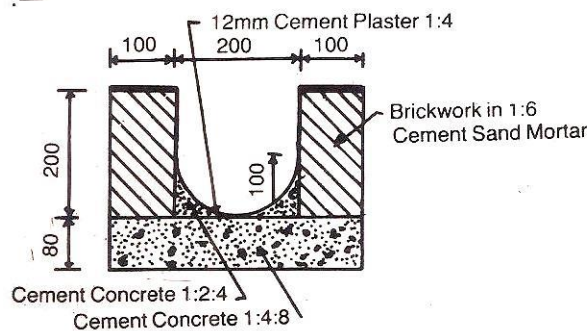

8. Calculate the quantities of all items for the construction of a retaining wall for the length of 20m.

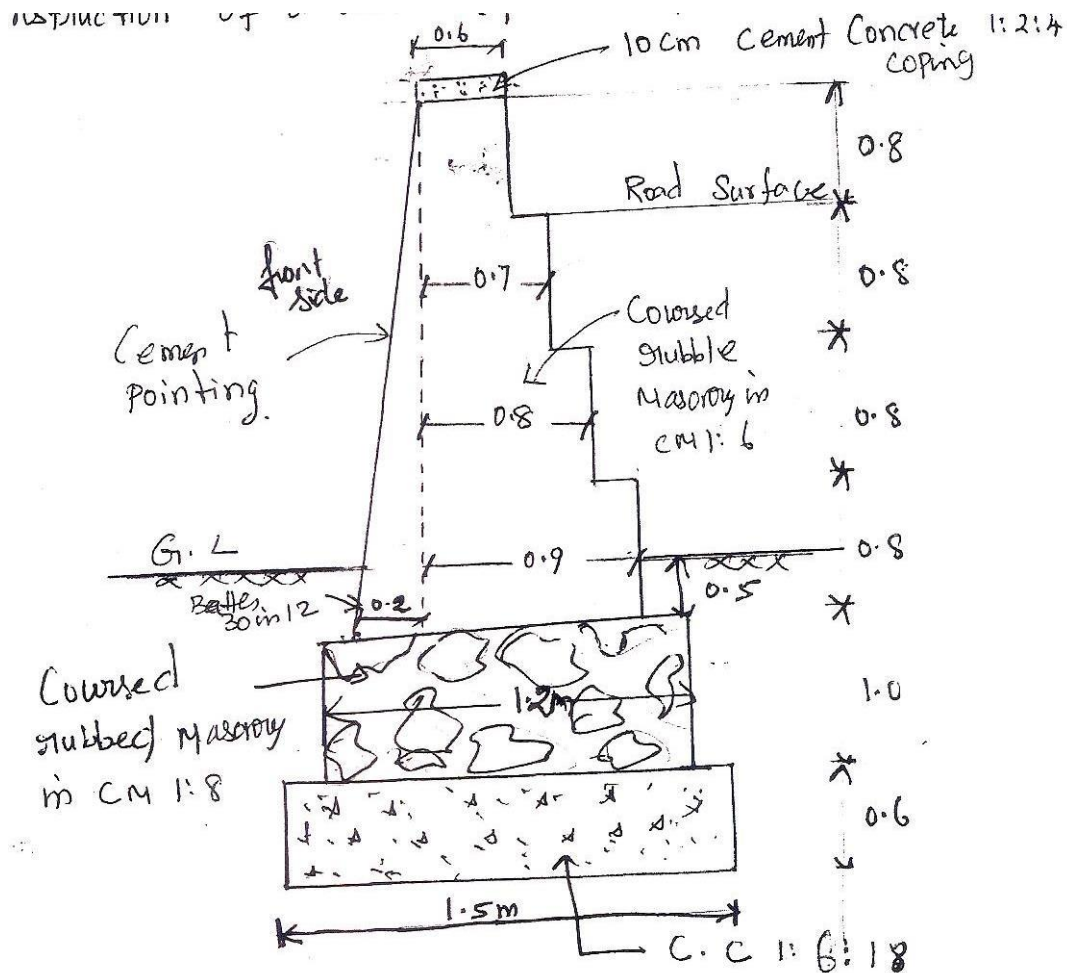

9. What material is required for laying a water supply line and sanitary fittings in a domestic building?

10. Prepare a detailed estimate for the construction of a macadam road for 1.5 km length having the following specifications.

- Formation width of the road - 10 m
- Average height of bank - 80cm
- Side slopes of bank - 2:1 (Horizontal: Vertical)
- Metalled width of road - 3.70 m

- Soling shall be of over burnt bricks laid flat.
- Intercoat of metalling shall be of stone ballast 12 cm thick loose layer compacted to 8cm.
- Top coat of metalling shall be of stone ballast 9 cm thick loose layer compacted to 6 cm. Side shall be provided with bricks on end edging.
- For bridges and culverts, and other miscellaneous items, provide lump sum amount Rs.50, 000/- per kilometer.

Assume rates as prevalent in your locality.

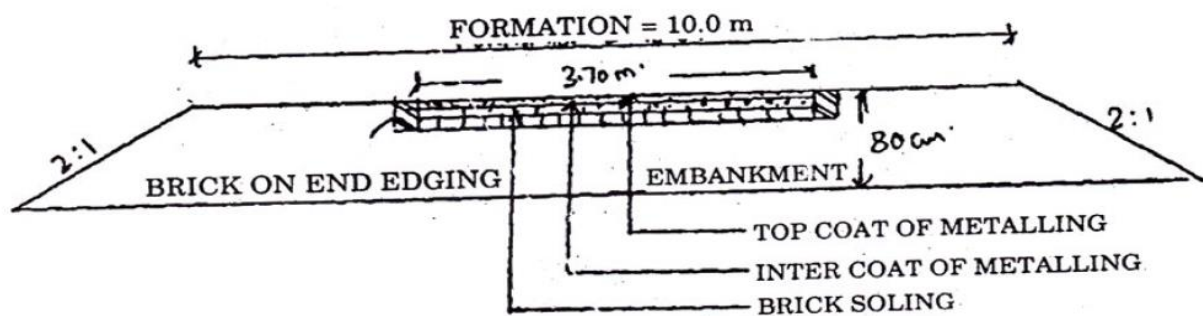

UNIT III SPECIFICATIONS AND TENDERS

Data – Schedule of rates – Analysis of rates – Specifications – sources –
Preparation of detailed and general specifications – Tenders – TTT Act – e-tender –
Preparation of Tender Notice and Document – Contracts – Types of contracts –
Drafting of contract documents – Arbitration and legal requirements.

2-MARKS

1. List the reason for rejection of tender. (May /June 2016, April / May 2015)

- The contractor does not fulfill the terms & conditions of the contract or if he left the work incompletes or if he does not maintain progress or if he does not observe the rules & instruction etc.

2. List the qualities of an arbitrator.(May /June 2016, April / May 2015)

- An arbitrator has to give the right decision for the settlement of disputes.
- Government officials are appointed as an arbitrator.(Officials from PWD or retired Judge)

3. Write about analysis of rates. (Nov/Dec 2015, Nov/Dec 2014) (Nov/Dec 2017)

The determination of rate per unit of a particular item of work, from the cost of quantities of materials & the wages of labour & other miscellaneous for its completion is known as the analysis of rates.

4. Define purpose of specification. (May /June 2014)

Specification specifies or describes the nature and the class of the work, materials to be used in the work, workmanship, etc., and it is very important for the execution of work. The cost of work depends much on specification.

5. List out the types of contracts? (May /June 2014)

- i. Lump sum contract
- ii. Lump sum & schedule contract
- iii. Schedule contract or Item rate contract
- iv. Labour contract
- v. Cost plus percentage contract
- vi. Rate contract
- vii. Material supply contract.

6. What are the data necessary for the preparation of tenders? (Nov/Dec 2014)

- 1. Drawings
- 2. Specifications
- 3. Cost of materials
- 4. Estimate

7. What is the qualification of a contractor? (Nov/Dec 2013)

SSLC with five years experience in construction or Diploma with 3 years experience in construction field.

8. Write standard size of batch box or Farma. (Nov/Dec 2013)

$$\begin{aligned} \text{Standard size of Batch box (or) Farma} &= 1\text{ft} \times 1\text{ft} \times 1.25\text{ft} &&= 1.25 \text{ cu. ft} \\ &= 0.3048 \times 0.3048 \times 0.381 &&= 0.0353 \text{ cu.m} \end{aligned}$$

9. State the general specification of damp proof course. (May/June 2013)

D.P.C shall be 2.5cm thick cement concrete 1:1 1/2:3 mixed with standard water proofing materials as specified & Painted with two coats of bitumen.

10. What is earnest money deposit? (May/June 2013, May/June 2009)

While submitting a tender the contractor is to deposit a certain amount 2 % of the estimated cost with the department. That is earnest money as guarantee of the tender. This is known as earnest money.

11. What is the object of specification? (May/June 2014)

- i. Quality
- ii. Instruction
- iii. Aim of the project

12. What is prime cost? (Nov/Dec 2011)

Prime cost is the actual cost of articles at shop and refers to supply of articles only and not to the carrying out of work. It is not always possible at the time of estimate and even entering contract to specify exactly the types of articles required.

13. What do you mean by overhead expenses? (Nov/Dec 2010) (Nov/Dec 2017)

Overhead costs include general office expenses rents, axes, supervision & other cost which are indirect expenses & not productive expenses on the job.

14. What is Lump sum contract? (May/June 2009/ Nov/Dec 2011/ May/June 2012)

In lump sum contract the contractor undertakes the construction of a specific work with all its contingencies to complete it in all respects with a specified time for a fixed amount.

15. What is revenue income? (May/June 2012)

Revenue is the gross increase in owner's equity resulting from the operations and other activities of the business. It is calculated by multiplying the price of goods or services are sold by quantity.

16-MARKS

1. Describe the detailed specifications of various items of works. (May / June 2016, Nov / Dec 2015)

- a. Reinforced cement concrete
- b. Colour washing
- c. Brick work 1st class

- d. Plastering cement mortar**
- 2. Describe the detailed specifications of the following. (Nov / Dec 2013)**
 - a. Cement concrete in foundation**
 - b. Plastering in cement mortar 1:6**
 - c. DPC course**
 - 3. Describe the detailed specification for Road work.**
 - 4. Describe briefly about arbitration. (May / June 2016, Nov / Dec 2015, May / June 2013) (8 Marks)**
 - 5. Explain the various types of contract system. (May / June 2016, Nov / Dec 2015, May / June 2013)**
 - 6. Describe briefly about tender. (Nov/ Dec 2015, May / June 2013)**
 - 7. Explain different types of specification. (8 marks) (May / June 2014)**
 - 8. Explain the legal requirements for Tenders. (Nov/Dec2014)**
 - 9. Explain the sequential procedure of opening of Tenders. (8 marks) (Nov / Dec 2013)**
 - 10. Write down the general specification of modern road.**

IV UNIT

Necessity – Basics of value engineering – Capitalized value – Depreciation – Escalation – Value of building – Calculation of Standard rent – Mortgage – Lease

(2 Marks)

1. What is scrap value? (Nov/Dec2011)

- Scrap value is the value of dismantled materials.
- For a building when the life is over at the end of its utility period the dismantled materials as steel, bricks, timber, etc., will get (fetch) a certain amount which is scrap value of the building.

2. What is book value of the property? (Nov/Dec2011)

- Book Value is the amount shown in the account book after allowing necessary depreciations.
- The book value of a property at a particular year is the original cost minus the amount of depreciation up to the previous year.

3. What is Obsolescence? (Nov/Dec2011, May/June 2004)

- The value of a property or structures become less by its becoming out of date in style, in structure, in design etc. and this is termed as Obsolescence.

4. What is Market value? (May/June 2012, May/June 2015, Nov /Dec 2015)

- The Market value of a property is the amount which can be obtained at any particular time from the open market if the property is put for sale.
- The market value will differ from time to time according to demand and supply.
- The market value also changes from time to time for various miscellaneous reasons such as changes in industry, changes on fashions, means of transport, cost of materials and labour etc.

5. What is Sinking fund? (May/June 2012, Nov /Dec 2013)

- The fund which is gradually accumulated by way of periodic or annual deposit for the replacement of the building or structure at the end of its useful life is termed as sinking fund.

6. Define lease. (Nov/Dec 2010, May/June 2014)

- The owner of the freehold property may give permission to any other person to use his freehold property for a certain number of years, on certain annual payments and other conditions, which is known as giving property on lease.

7. What is Annuity? (May/June 2009)

- Annuity is the annual periodic payments for repayments of the capital amount invested by a party.

- These annual payments are either paid at the end of the year at the beginning of the year, usually for a specified number of years.

8. What is Capital cost? (May/June 2004, May/June 2009)

- Capital cost is the total cost of construction including land, or the original total amount required to possess a property.
- It is the original cost and does not change, while value of a property is the present cost which may be calculated by methods of valuation.

9. What is Salvage value? (May/June 2004)

- It is the value at the end of the utility period without being dismantled.
- A machine after the completion of its usual span of life or when it becomes uneconomic may be sold and one may purchase the same for some other purpose, the sale value of the machine is the Salvage value.
- It does not include the cost removal, sale, etc.

10. What is Outgoing? May/June 2004

- Outgoings or the expenses which are required to be incurred to maintain the revenue of the building.
- Out goings are deducted from the gross income to get the net income of a property.

11. Define depreciation. /What is mean by depreciation? (May/June 2008, Nov/Dec 2014)

- Depreciation is the gradual exhaustion of the usefulness of a property.
- This may be defined as the decrease or loss in the value of a property due to structural deterioration use, life wear & tear, decay and obsolescence.

12. Define valuation (May/June 2008)

- Valuation is the technique of estimating or determining the fair price or value of a property such as a building, a factory, and other engineering structures etc., by valuation the present value of property is determined.

13. What are the important factors influencing the value of building?

- i) Type of the building
- ii) Location of the building
- iii) Expected life of the building
- iv) Size and shape of the building
- v) The Present condition of the building

14. Define evaluation.

- Valuation is the process of estimating the cost of a property based on its present condition.
- The properties may be immovable properties like land, buildings, mines trees quarries etc., and movable properties such as coal, oil, steel, cement, sand etc.

15. What is called Tender Notice?

The notice inviting tender is called tender notice.

SIXTEEN MARK QUESTION AND ANSWER

1. Explain the four method of calculating depreciation. (May/June 2012, May/June 2014, May/June 2015)

2. Explain any four methods of calculating valuation. (May/June 2009, May/June 2012, May/June 2014)

3. Explain different forms of value. (Nov/Dec 2013, May/June 2014)

4. Explain the four method of calculating depreciation. (May/June 2012, May/June 2013)

5. Calculate the standard rent of a government residential building newly constructed from the following data: (Nov/Dec 2011)

- a) Cost of land – Rs. 10,000
- b) Cost of construction of the building – Rs. 40,000
- c) Cost of roads within the compound and fencing – Rs. 2,000
- d) Cost of electric installation including fans – 8% of cost of building
- e) Cost of electric installation including fans – 10% of cost of building
- f) Municipal house tax – Rs. 400 per annum
- g) Water tax – Rs. 250 per annum
- h) Property tax – Rs. 140 per annum

6. In a plot of land costing Rs. 20000 a building has been newly constructed at a total cost of Rs. 80000 including sanitary and water supply works, electric installation, etc. The building consists of four flats for four tenants. The owner expects 8% return on the cost of construction and 5%return on the cost of land. Calculate the standard rent for each flat of building assuming: (May/June 2014)

- i) The life of the building as 60 years and sinking fund will be created on 4% interest basis
- ii) Annual repairs cost at 1% of the cost of construction
- iii) Other outgoing including taxes at 30% of the net return on the building.

7. Explain the following: (Nov/Dec 2012)

- i) Types of lease
- ii) Mortgage
- iii) Methods of depreciation
- iv) Escalation

8. Explain the Sequential procedure for opening of tenders. (8 Marks) (Nov/Dec 2013)

9. Explain different forms of value. (Nov/Dec 2013)

10. Explain the step involved in the standard rent of the building (Nov/Dec 2014)

UNIT V - REPORT PREPARATION

Principles for report preparation – Report on estimate of residential building – Culvert- Road- Water supply and sanitary installations – Tube well- Open wells.

2-MARKS

1. What is the importance of report preparation? (May / June 2016, May / June 2014)

The report should be written in such a manner that on the study of the report one can form an idea, about the whole work. The report must be given at the beginning of the estimate followed by calculations, design, general and detailed specifications, analysis of rates etc.,

2. Why is valuation necessary? (May / June 2016, May / June 2014)

Valuation is necessary for the following:

1. Buying or selling property
2. Taxation
3. Rent Fixation
4. Security of Loans or Mortgage
5. Compulsory acquisition

3. Write the principles of report preparation. (Nov/ Dec 2015, May / June 2015)

The principles of report writing are

- ✓ Report should be written in such a manner that on the study of the report one can form an idea.
- ✓ The report of each work must differ from the other.
- ✓ It should be written according to the nature of the work.
- ✓ The report must be given at the beginning of the estimate followed by calculations, design, general and detailed specifications, analysis of rates etc.,

4. Give a note about any two principles for the preparation of water supply scheme. (Nov/ Dec 2015)

- i) Selection of source
- ii) Quality of water
- iii) Disinfection
- iv) Simple drip- feed device
- v) Pressure feed Chlorinators
- vi) Structure for infiltration galleries.

5. Enumerate the documents that accompany a report. (May / June 2015)

- 1. Preliminary investigation, Reconnaissance, preliminary survey, Trial boring soil testing etc.
- 2. Preparation of preliminary estimate and obtaining administrative approval.
- 3. Selection of site or alignment.
- 4. Surveying - plan table survey levelling contouring etc.

6. Differentiate Tube well and open well. (May / June 2014)

Tube Well	Open Well
Casing is of galvanized iron.	Casing is of PVC.
Used in where there is a collapsible soft rock or alluvial soil.	Used in where there is a non - collapsible hard rock.
Casing does not go completely into the bore hole and goes only until hard rock.	Casing goes for deeper

7. What are the types of leases? (Nov/ Dec 2013)

- i. Building lease
- ii. Occupation lease
- iii. Life lease
- iv. Perpetual lease

v. Sub lease

8. What is Measurement Book? (Nov/ Dec 2013)

The measurements of all works and supplies are recorded in the measurement book Form No.23 and payment of all works and supplies are made on the basis of measurement recorded. The measurement books are very important account records.

9. Give the estimate for the sanitary installation. (May / June 2013)

Supplying and fixing including water connection, overhead tank of 50 gls, (22liters). And sewer connection to a distance of 30.5ft. (10m).

10. What is annuity? (May / June 2009)

Annuity is the annual periodic payments for repayments of the capital amount invested by a party. These annual payments are either paid at the end of the year at the beginning of the year, usually for a specified number of years.

11. What is capital cost? (May / June 2009)

The total cost of the construction of the project including land is called capital cost.

12. Define Lease. (Nov/ Dec 2010)

An owner can borrow money against the security of his property, & for that purpose he is required an interest to the party advancing the loan. The loan is required to be returned in specified time.

13. What is book value of the property? (Nov/ Dec 2012)

Book Value is the amount shown in the account book after allowing necessary depreciations. The book value of a property at a particular year is the original cost minus the amount of depreciation up to the previous year.

14. Define the Obsolescence. (May/ June 2013)

The value of a property or structures become less by its becoming out of date in style, in structure, in design etc. and this is termed as Obsolescence.

15. What is Revenue Income? (May/ June 2012)

Revenue is the gross increase in owner's equity resulting from the operations and other activities of the business. It is calculated by multiplying the price of goods or services are sold by quantity.

16-MARKS

1. Explain the procedure for preparation of reports. (May / June 2016)
2. Prepare a report on estimate for construction of a Culvert. (May / June 2016, May/ June 2014, Nov/Dec2011)
3. Prepare a report on estimate for construction of Residential building. (Nov/ Dec 2015, Nov/Dec2013, Nov/Dec2011)
4. Describe the principles for the preparation of water supply scheme. (Nov/ Dec 2015)
5. Write a model report on estimation of roads. (Nov/ Dec 2015, May/June 2013, Nov/Dec2011)
6. Prepare a report on estimate for construction of Distributing – Irrigation channel Nov/Dec2011
7. What are the points to be considered in the report writing and explain the residential building report? (May/ June 2013)
8. Explain the procedure for preparation of reports. (May / June 2016)
9. Prepare a report on estimate for construction of a Culvert. (May / June 2016, May/ June 2014, Nov/Dec2011)
10. Prepare a report on estimate for construction of Residential building. (Nov2015, Nov/Dec2013, Nov/Dec2011)